

W2.06A

PROJECTILES A

[A] Find the range (Δs_x) for each of the following projectiles. [B] Find the magnitude & direction of the ball's velocity the instant before it strikes the ground.

1]

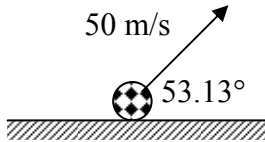

2]

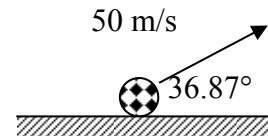

3]

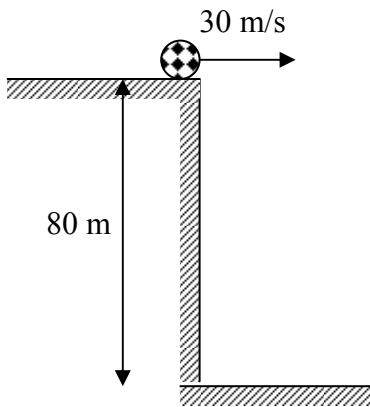

4]

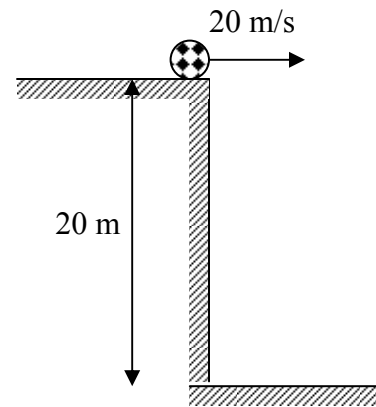

5]

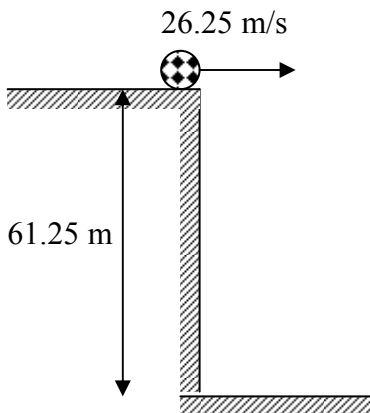

6]

