

W3.09

Quick-Hit Newton's Law Problems 1

1. If the acceleration of a body is zero, are forces acting on it?
2. Why do you push harder on the pedals of a bicycle when first starting out than when moving at a constant speed? There are two reasons.
3. When a golf ball is dropped on the pavement, it bounces back up. (A) Is a force need to make it bounce back up? (B) If so, what exerts the force? (C) How does this force compare to the golf ball's weight?
4. Why might your foot hurt if you kick a heavy desk or a wall? Explain using the appropriate Newtonian Law.
5. The force of gravity on a 2-kilogram rock is twice as great as that on a 1 kilogram rock. Why then doesn't the heavier rock fall faster?
6. According to Newton's third law, each team in a tug of war pulls with equal force on the other team. What, then, determines which team will win?
7. Sketch the free-body diagram of a softball (A) at the moment it is hit by the bat, and again (B) after it has left the bat and is flying towards the outfield.
8. If the coefficient of kinetic friction between a 35-kilogram crate and the floor is 0.30, what horizontal force is required to move the crate at a steady speed across the floor? What horizontal force is required if μ_k is zero?
9. A cup of coffee on the dashboard of a car slides forward on the dash when the driver accelerates from 40 km/h to rest in 3.5 seconds or less, but not if she accelerates in a longer time. What is the coefficient of static friction between the cup and the dash?

Review Problems (Challenging)

- The system pictured below is in equilibrium, but begins to slip if an additional mass is added to the 5.0-kg object. What is the coefficient of static friction between the 10-kg block and the plane on which it rests?

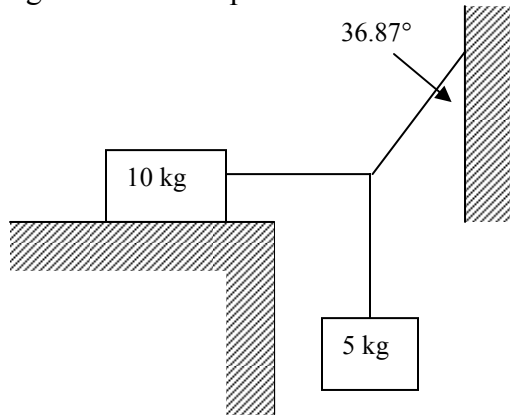

- The system below is in equilibrium with the string in the center “exactly” horizontal. Find the angle θ and the tension in each string. (Hint: Do 2 free body diagrams, one at each knot.)

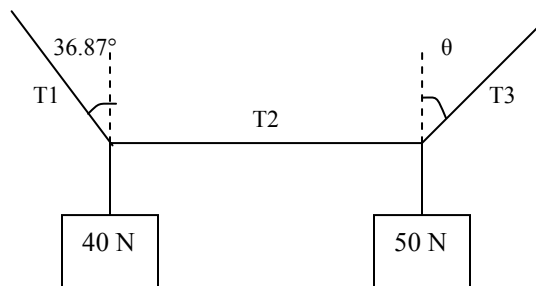

- The force, F , is just sufficient to hold the 14-N block and weightless pulleys in equilibrium. There is no appreciable friction between the cables and pulleys. Calculate the tension, T , in the upper cable

